

*Tideland Signal Corp.*

*featuring Aids to Navigation Products*

## 8.1 GRP Towers and Steel Structures

01	UPDATE	03.03.2008	CWQ
00	RELEASE	01.20.2008	CWQ
<b>Rev</b>	<b>Description</b>	<b>Date</b>	<b>By</b>

## A. GRP Tower Systems

Tideland's GRP (glass reinforced plastic) towers are modular structures made of precision-molded GRP sections with a color-impregnated gel coat exterior and an unpolished interior. Colors are in accordance with IALA marking standards. The towers can be installed in a wide variety of terrains and can withstand winds of up to 200 km/h (125 mph) when anchored properly to a concrete foundation mat of an approved design and construction. The towers feature a lightning rod system for protection of both tower and mounted equipment.

Tower sections are packed in sturdy shipping crates for ease of transport and are assembled locally with the aid of simple hand tools. Tideland provides all required assembly hardware and complete instructions for constructing the foundation mat and assembling the tower. Entry into an assembled tower is possible through a swing door, and the service floor is accessible by means of an interior ladder and a hatch.

A Tideland GRP tower system serves as a day mark and supports radar reflectors, a solar-charged battery system for powering aids to marine navigation, a signal light, and/or a racon.

### LT-10 TOWER SYSTEM

The support structure for an LT-10 Tower System is Tideland's 10-meter GRP tower, available with exterior colors to meet day mark requirements or in a neutral color having no lateral significance. The LT-10 tower can support aids to navigation such as the following:

- Interior or exterior radar reflector units.
- Fixed or rotating beacons. Mounted atop this tower, Tideland can provide a range of lanterns with visible ranges exceeding 23 nautical miles.
- SeaBeacon 2 System 6 Racon.
- A bank of secondary batteries housed in a tray in the base of the tower. These batteries power equipment mounted on the tower.
- A solar array mounted atop the tower. The array charges the battery bank.

The LT-10 tower comes complete with specifications for a foundation mat that will anchor the tower securely and sustain winds of up to 200 km/h (125 mph)

### LT-15 TOWER SYSTEM

For major light applications, Tideland offers the LT-15 Tower System, which differs from the LT-10 tower system on only a few points. The support structure for the LT-15 system is a 15-meter GRP tower that will accommodate most major beacons. It features a pedestal for mounting any aid to marine navigation and a secure handrail.

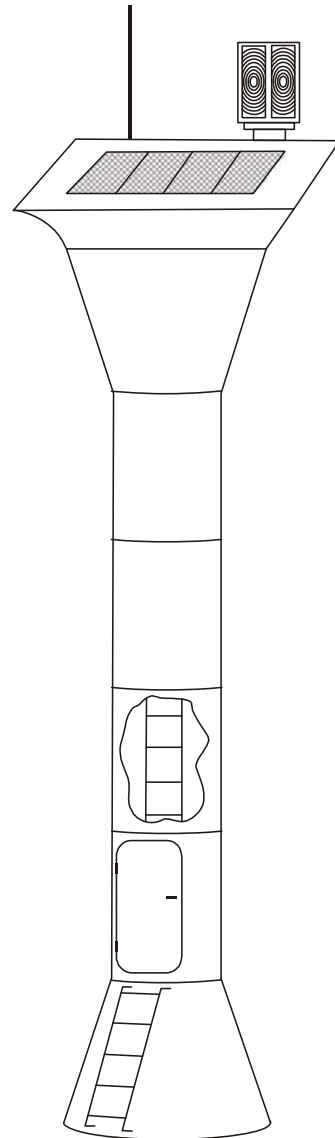

## B. Galvanized Steel Towers and Monopoles

---

Typical tower showing lantern and solar system.

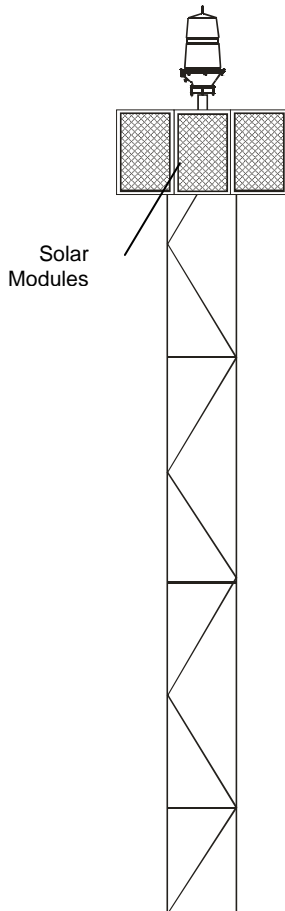

Larger towers are often used for range light and day mark applications.

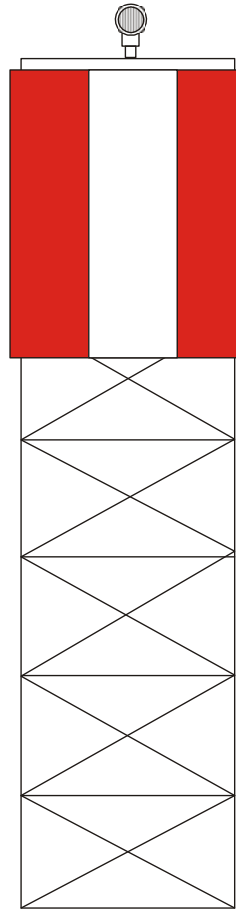

Monopoles are popular in certain locations.



Tideland Signal has numerous designs of galvanized lattice towers and monopoles. A few samples are shown above. All towers are modular in construction to facilitate shipping and handling on site. Generally lattice towers and monopoles are used for heights greater than 5m or where large day marks are required for use with range lights.

Monopole towers are also available hinged so that the tower can be easily lowered for maintenance of the lantern.

## C. Pedestals and Stanchions

Tideland offers a full line of pedestals and stanchions for mounting marine signal lanterns in any required configuration. All welds are continuous and either inert gas-shielded arc or coated rod. Pedestals and stanchions are constructed of hot-dipped galvanized steel or aluminum.

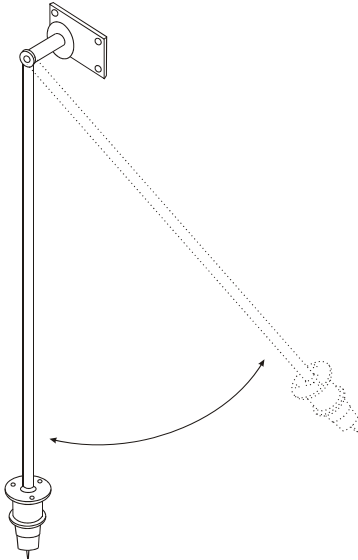

Swing pedestals are popular for use on bridges. The lantern hangs down below the bridge indicating the navigation channel. For maintenance the lantern is simply swung up to a comfortable position for maintenance.

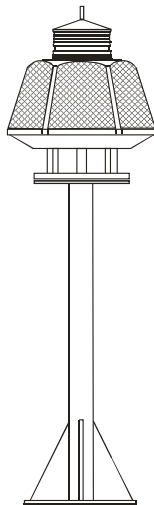

Self contained lanterns are becoming increasingly popular for lights up to 5Nm and, in some cases, 7Nm. The pedestal used on a self contained light is available from 1m high up to 3m as standard with options up to 5m.

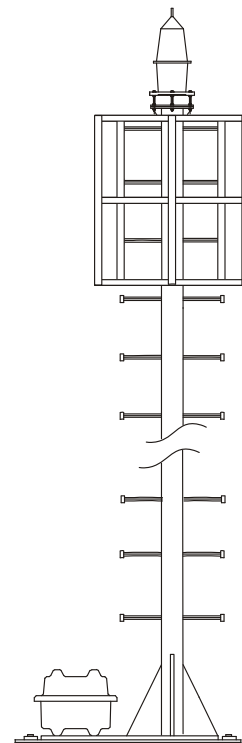

Other options of pedestal include those using conventional lanterns, solar and batteries. This example is a 4m high pedestal which also includes climbing rungs and a safety hoop at the top.

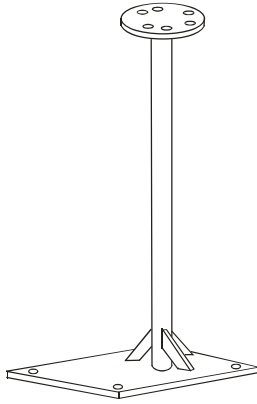

A typical galvanized steel pedestal that will accept all Tideland Signal lanterns.

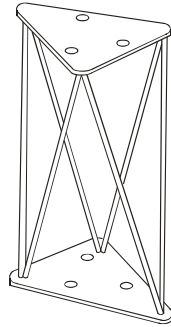

A lantern guard for use with all Tideland Signal lanterns. This guard protects the lantern but also provides a convenient mount for an IALA recommended top mark.

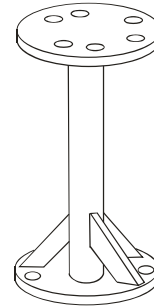

Small pedestals come in a variety of heights from 150mm tall to several meters tall. Ideal for mounting a light on a bridge abutment for example.

## D. Radar Reflectors

Radar reflectors are passive devices designed to reflect a maximum amount of radar energy and are fitted in most of the larger polyethylene buoys supplied by Tideland Signal. The design of corner reflectors is based upon the principle that radar energy reflects well from flat surfaces. Tideland corner reflectors therefore present many faces to a radar pulse.

Standard reflectors provide a surface area of  $10\text{m}^2$  or greater and come in a variety of shapes and sizes as shown below. Some are molded within the polyethylene buoy and some are fitted to its structure.

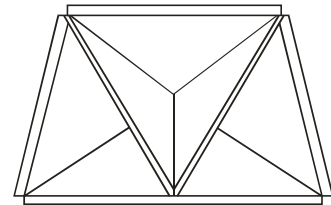
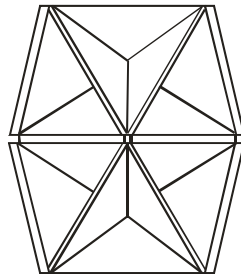
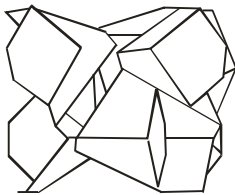

This octahedral radar reflector is designed for use with Tideland Signal lanterns and provides a radar target area of  $35\text{m}^2$ . It can be used on fixed or moving installations such as beacons, channel markers or buoys. Manufactured from aluminum it provides an enhanced radar image. Normally the reflector is bolted to the structure and the lantern fitted to the top plate by means of stainless steel bolts.

